

205 CPU NETWORK ADAPTER F2-UNICON

Network Adapter

The F2-UNICON Network Adapter is used to place **Automationdirect.com**[™] DL205 CPUs (except D2-230 and D2-250) on a RS-422 or RS-485 multi-drop network. The Network Adapter converts RS-232 signal levels to RS-422 or RS-485 signal levels. The adapter supports all **Automationdirect.com** protocols.

Hardware Features

- ✓ Flexible mounting and the included cable make the Network Adapter very easy to install.
- ✓ No external power is required. The 5V power connection is made inside the communication cable connected to the PLC CPU.
- ✓ Network connections have substantial transient over-voltage protection.
- ✓ Both four wire plus ground (RS-422 full duplex) and two wire plus ground (RS-485 half duplex) networks are supported.
- ✓ The termination resistors required at the extreme ends of the network are built-in.
- ✓ Built-in bias resistors prevent reception of erroneous data when the network is idle (all receiver inputs are floating when no transmitter on the network is active).
- ✓ Transmit and receive LED indicators simplify troubleshooting.
- ✓ Designed and tested with **Automationdirect.com** PLCs for use in a noisy industrial environment.

[™]**Automationdirect.com** is a Trademark of **Automationdirect.com**.

Copyright © 1991, FACTS Engineering Inc., 8049 Photonics Dr, New Port Richey, FL. 34655.

Date of Publication October 1999.



Order Number: F2-UNICON-M

Network Adapter Connections

The connection between the PLC CPU and the Adapter is made using the supplied one foot modular cable.

The connection to the RS-422 or RS-485 multi-drop network is made at a six position European style screw terminal block.

Mounting

The F2-UNICON Network Adapter may be mounted three different ways.

- 1) Panel mount next to the CPU.
- 2) Din #3 rail or A Series rail mount using the supplied hardware.
- 3) Attach to the side of the PLC using the supplied high temperature adhesive backed dual lock reclosable fastener system.

Specifications

Maximum Network Cable Length	4000 ft	
Maximum Data Rate (bits per sec.)	115,200	
Maximum Driver Load	62 S	
Network Driver Voltage	±1.5V minimum	
Min. Network Driver Active State	RXD+ 1.5V less than RXD-	
Current from CPU +5Vdc Supply	No Load	65 mA
	Typical	100 mA (120 S Termination)
Operating Temperature	0 to 60°C	

Network Configuration

RS-422 and RS-485 networks must be connected in a true daisy-chain configuration to avoid data errors. The network must form a single continuous path as shown in the following good network configurations a, b, and c.

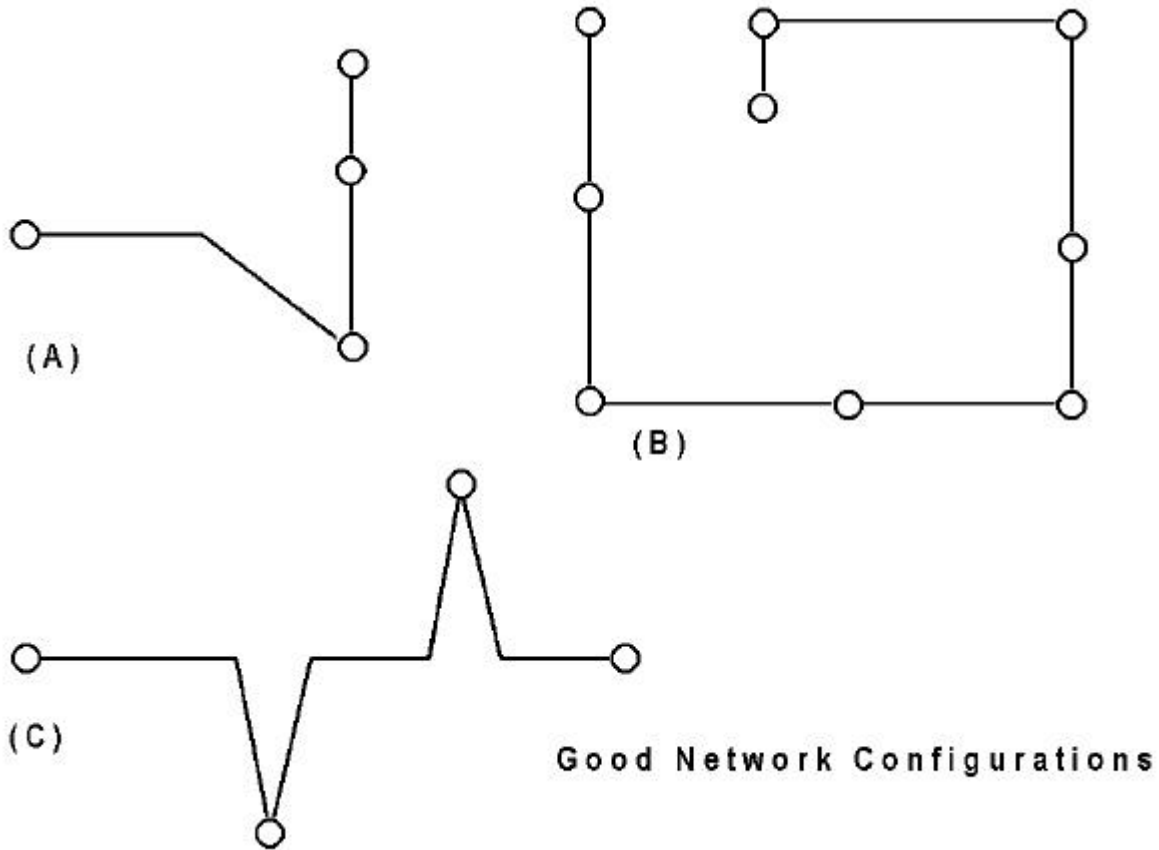

Do not create a network with long branches, spokes, or subs as shown in the following bad network configuration.

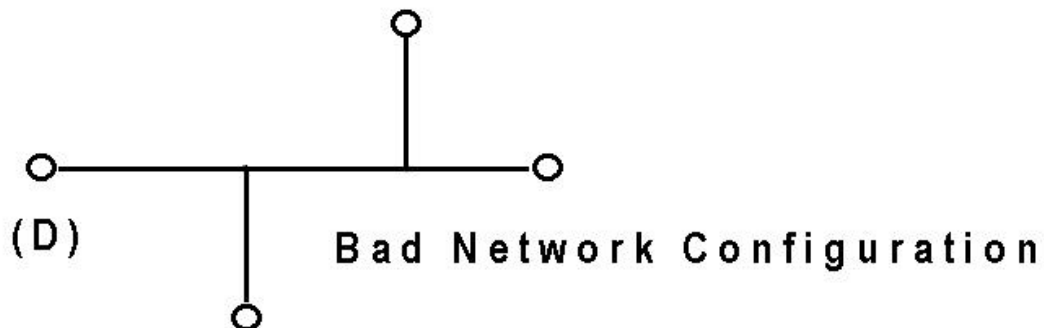

F2-UNICON Jumper Placements

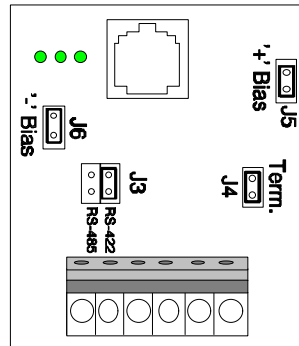

RS-422 Jumper locations for units on extreme ends of the network.

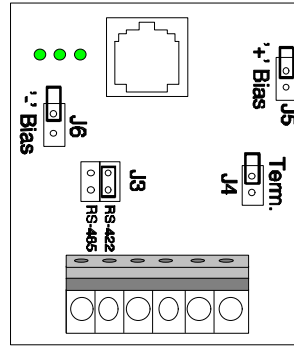

RS-422 Jumper locations for units on intermediate drops of the network.

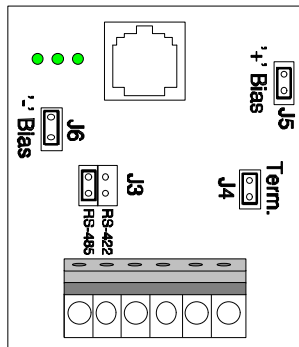

RS-485 Jumper locations for units on extreme ends of the network.

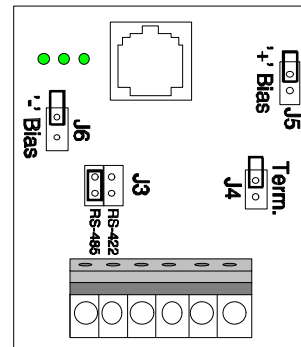

RS-485 Jumper locations for units on intermediate drops of the network.

PC to F2-UNICON Wiring Diagram (RS-422)

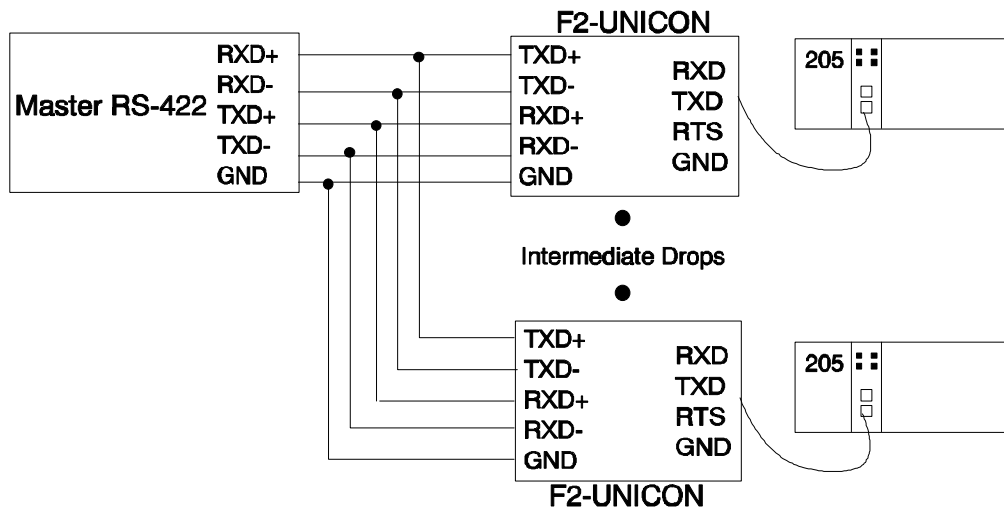

FA-UNICON to F2-UNICON Wiring Diagram (RS-422)

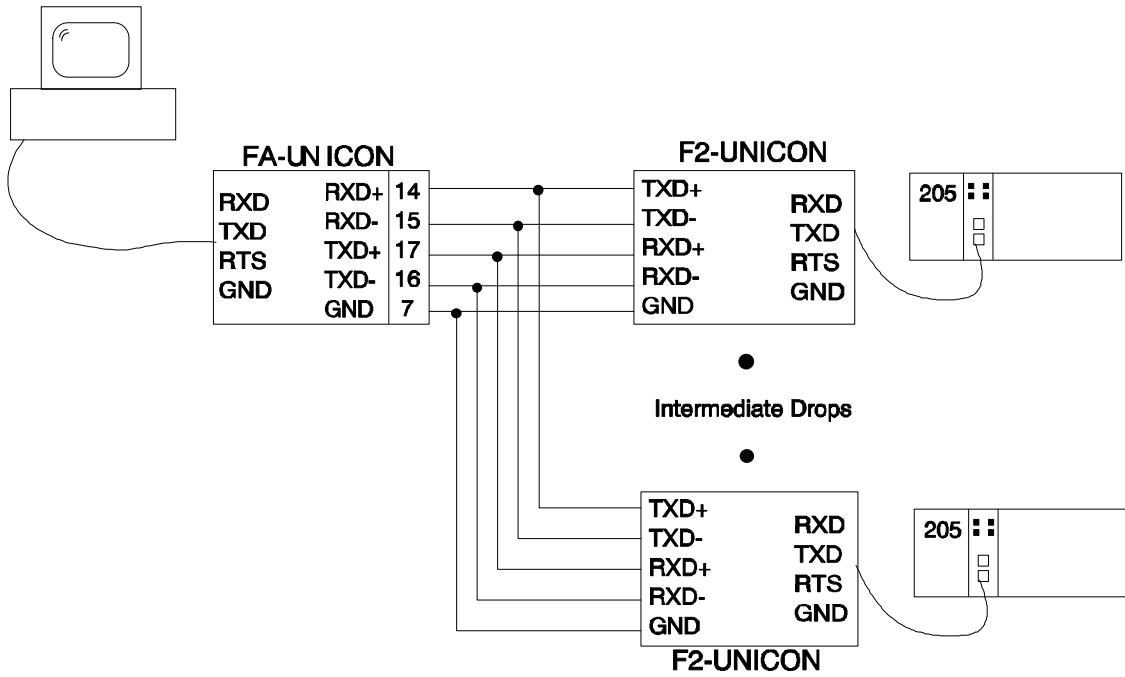

FA-ISONET to F2-UNICON Wiring Diagram (RS-485)

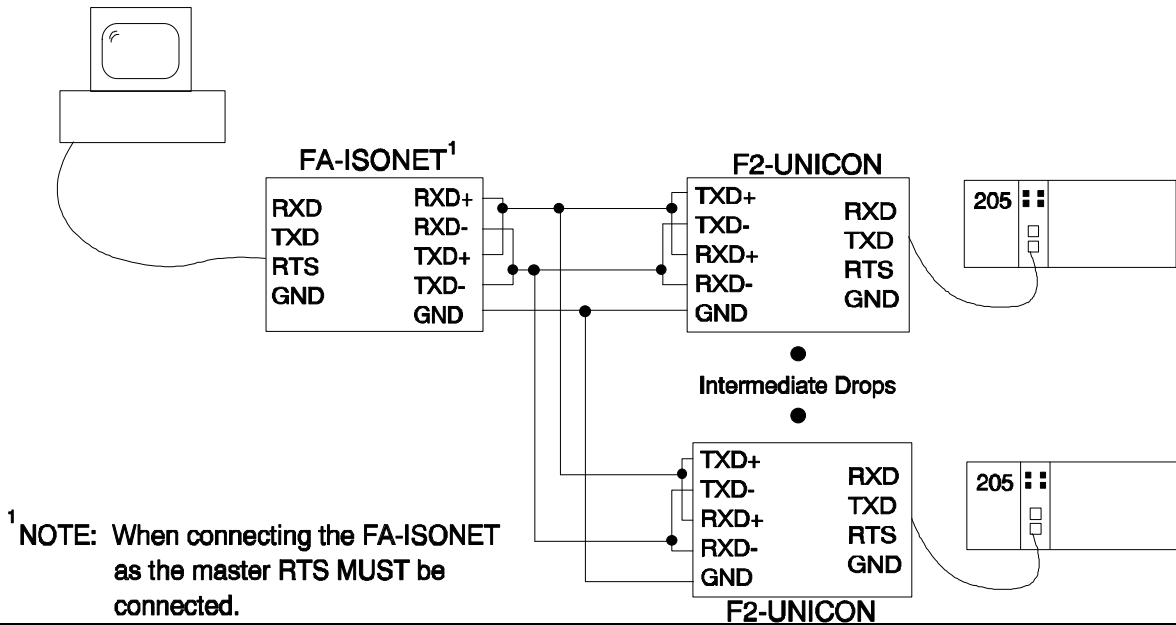

Connecting Cables and Line Termination

A dual, RS-422, or single, RS-485, shielded twisted pair plus ground connection between devices is recommended. Proper termination of the balanced transmission line is required to prevent data errors. A typical AWG 22 solid wire with .060 inch plastic cover, twisted 4.5 times per foot has a characteristic impedance of about 120 Ω. Termination must only be done at the extreme end of the cable runs. Addition of intermediate terminations will adversely load the line.

To install a 120Ω termination resistor, position a shunt over the two "J4" pins labeled "120 ohm TERM." (see page 4). Place the jumper on a single post for all intermediate drops along the network (factory default).

Cable Shielding

Shielding improves noise immunity (magnetic field protection).

It is important to ground the shield at one end only. Grounding both ends of the shield will cause magnetic field induced noised currents to flow through ground. Noise may then appear on the data lines due to transformer like coupling with the shield.

If the cable shield must be used as the system ground conductor then placing a 100 Ω resistor in series with the shield and the ground connection will reduce noise producing ground currents.

RS-422 Selection

To connect the PLC CPU to a RS-422 network, position the "J3" shunt on the two pins labeled "RS-422" (factory default).

RS-485 Selection

To connect the PLC CPU to a RS-485 network, position the "J3" shunt on the two pins labeled "RS-485" (see page 4). In this position, the receive circuit is disabled whenever the PLC CPU is transmitting (half duplex, no echo).

Install wire jumpers on the terminal block from "RXD-" to "TXD-" and from "RXD+" to "TXD+". This converts the F2-UNICON from a four wire to a two wire connection.

Network Biasing

For optimum performance, RS-422 and RS-485 receivers should be in the inactive state (mark) when their inputs are open or floating. A receiver's inputs will be floating when all transmitters on the network are disabled. The F2-UNICON includes bias resistors to force the receivers into the inactive state when the network is idle. The network biasing must only be done at the extreme ends of the cable runs.

To install the bias resistors, position a shunt over the two "J5" and "J6" pins labeled "+ BIAS" and "- BIAS" (see page 4). Place the jumpers on a single post for all intermediate drops along the network (factory default).

If the RS-422/485 driver of the network master is always enabled then the last slave does not need to be biased. In all other configurations it is normally better to bias the network at both ends. Many host computer software packages will not work without network biasing resistors on the host computer RS-422 or RS-485 receivers.

F2-UNICON Components

- (A) F2-UNICON Network Adapter PCB
- (B) Mounting rail for PCB
- (C) DIN #3 rail bracket for mounting rail
- (D) Dual lock reclosable fastener system for mounting rail
- (E) One foot reverse modular cable with two RJ12 6P6C plugs to connect F2-UNICON Network Adapter to the bottom network port on 205 PLC CPUs