

FACTS engineering

Automationdirect.com[™]

Direct Logic 405

SDS[™] Network Master

Smart Distributed

System Module

F4-SDS



Order Number: F4-SDS-M

TRADEMARKS

TM**Automationdirect.com** is a Trademark of **Automationdirect.com** incorporated.

TMCoProcessor is a Trademark of FACTS Engineering, Inc.

COPYRIGHT

Copyright 1994, FACTS Engineering Inc., 8049 Photonics Dr., New Port Richey, Florida, 34655.. World rights reserved. No part of this publication may be stored in a retrieval system, transmitted, or reproduced in any way, including but not limited to photocopy photograph, magnetic or other recording media, without the prior agreement and written permission of FACTS Engineering, Inc.

Last Issued Date: October 1994
Current Issued Date: December 1999

WARNING

Thank you for purchasing automation equipment from FACTS Engineering. We want your new FACTS Engineering automation equipment to operate safely. Anyone who installs or uses this equipment should read this publication (and any other relevant publications) before installing or operating the equipment.

To minimize the risk of potential safety problems, you should follow all applicable local and national codes that regulate the installation and operation of your equipment. These codes vary from area to area and usually change with time. It is your responsibility to determine which codes should be followed, and to verify that the equipment, installation, and operation is in compliance with the latest revision of these codes.

At a minimum, you should follow all applicable sections of the National Fire Code, National Electrical Code, and the codes of the National Electrical Manufacturers Association (NEMA). There may be local regulatory or government offices that can help determine which codes and standards are necessary for safe installation and operation.

Equipment damage or serious injury to personnel can result from the failure to follow all applicable codes and standards. We do not guarantee the products described in this publication are suitable for your particular application, nor do we assume any responsibility for your product design, installation, or operation.

If you have any questions concerning the installation or operation of this equipment, or if you need additional information, please call us at 1-800-783-3225.

This document is based on information available at the time of its publication. While efforts have been made to be accurate, the information contained herein does not purport to cover all details or variations in hardware and software, nor to provide for every possible contingency in connection with installation, operation, and maintenance. Features may be described herein which are not present in all hardware and software systems. FACTS Engineering assumes no obligation of notice to holders of this document with respect to changes subsequently made. FACTS Engineering retains the right to make changes to hardware and software at any time, without notice. FACTS Engineering makes no representation or warranty, expressed, implied, or statutory with respect to, and assumes no responsibility for the accuracy, completeness, sufficiency, or usefulness of the information contained herein. No warranties of merchantability of fitness for purpose shall apply.

TABLE OF CONTENTS

CHAPTER 1: INTRODUCTION	1.1
SDS NETWORK FEATURES	1.1
APPLICATIONS	1.1
SDS PROTOCOL FEATURES	1.2
Identification Data	1.2
Diagnostic Data	1.2
Operational Parameters	1.2
Extended Operations	1.3
High Performance	1.3
SDS Network Master Module Specifications, F4-SDS	1.4
CHAPTER 2: CONFIGURATION	2.1
SLOT DEPENDENT CONFIGURATION	2.1
Slot Dependent V-Memory Locations	2.1
Extended Operations Pointer	2.2
Communication Rate Code	2.2
Communication Rate Code Table	2.2
Error Code	2.3
Error Code Table	2.3
OnLine/OffLine Status Table Pointer	2.4
Extended SDS Bus Diagnostics	2.5
SDS NETWORK MASTER OPERATION RUNG	2.6
Slot Dependent BUSY Relay	2.6
Special Purpose (SP) Data Communications Relays	2.6
SDS Network Master Slot and Number of SDS Inputs	2.7
SDS Addressing Table	2.7
Number of SDS Outputs	2.8
SDS Addressing Table	2.8
Start Address of SDS Outputs	2.9
Start Address of SDS Inputs	2.9
Location of SDS Network Master Operation Rung	2.10
Example SDS Network Master V-Memory Map	2.12
CHAPTER 3: PORT CONNECTIONS AND NETWORK WIRING	3.1
SDS NETWORK MASTER CONNECTIONS	3.1
SDS BUS CONNECTION	3.2
APPENDIX A: TROUBLE SHOOTING	4.1
DESCRIPTION OF NORMAL OPERATION	4.1
COMMON SDS MASTER PROBLEMS AND SOLUTIONS	4.1

CHAPTER 1: INTRODUCTION

The SDS Network Master Module, F4-SDS, is the interface between a single Smart Distributed System of up to 64 intelligent SDS field devices and the DirectLogic DL405 PLC.

The SDS Network Master Module maps input devices directly into the DL405 X, C, GX or V-Memory locations. Output devices are directly mapped into DL405 Ys, Cs, or V-Memory locations.

SDS NETWORK FEATURES

The features of the SDS Network make it an ideal intelligent device network for the factory floor and other rugged applications.

- ✓ Low cost four wire installation is easy to install and maintain. Brad Harrison quick-disconnects eliminate installation errors when adding a device.
- ✓ Power is integrated into device wiring.
- ✓ Low cost network hardware originally developed for automobile systems such as anti-lock brakes (CAN bus).
- ✓ High-Information network provides advanced diagnostics and features.
- ✓ Response times to .10 msec per device.
- ✓ Industrially rugged and highly noise immune differential data transmission.
- ✓ Advanced error management and nondestructive arbitration with undetected bit error rates near zero.

APPLICATIONS

A SDS Network is typically used in distributed I/O installations such as conveyors and other applications where field devices are not concentrated. It is also used when an application requires one of the unique features or the advanced diagnostics provided by of the SDS Network.

Other PLC Direct networking options for reducing wiring costs include Slice I/O (16 points per drop) and Remote I/O (128 points per drop).

SDS PROTOCOL FEATURES

Each SDS device contains a data base which consists of identification data and diagnostic information. Each device data base also contains parameters which control the operation of the device. These features are summarized in the following table. The "Type" column indicates items which the SDS Network Master Module can Read Only (R), or can Read and Write (R/W).

Item	Description	Type
Identification Data		
Device Address	Unique SDS address for this device, 1-126	R
Vendor Identification	Number assigned to the manufacture of the device	R
Tag Name	Nick name assigned to the device by the user	R/W
Catalog Listing	Manufacture's order number	R
Device Name	Manufacture's device description or name	R
Vendor Name	Manufacture's name	R
Software Version	SDS device's software version number	R
Date Code	Manufacture's date code for the device	R
Serial Number	Manufacture's device serial number	R
Diagnostic Data		
Number of Operations	Counter used for maintenance purposes	R/W
Elapsed Time	Number of minutes the device has been operating	R/W
Power Cycles	Number of power cycles the device has experienced	R/W
Diagnostic Errors	Diagnostic Errors Counted during last self test	R
Sensor Diagnostics	32 Bus, Device, and Environmental error flags	R/W
Device Type	SDS General Class of device codes	R
Operational Parameters		
NO/NC	NO=0, NC=1 operation	R/W
On Delay Timer	De-bounce time in msec of ON change of state	R/W
Off Delay Timer	De-bounce time in msec of OFF change of state	R/W
Motion Detect Timer	ON-OFF and OFF-ON transitions reset the timer	R/W
Batch Counter	Number of operations before a change of state	R/W
Cyclical Timer	Maximum rate of change of state indications	R/W

Extended Operations

The FACTS Engineering SDS Network Master Module provides additional advanced capabilities.

- ✓ Eight devices can be configured as high speed counters.

Input transitions are accumulated by the SDS Network Master Module independently of the PLC scan.

Current count values are reported to the PLC each scan. Control bits are provided to run and reset each counter individually.

- ✓ The entire data base of a single device can be read into a user specified block of V-Memory with a single command.

Using DirectSoft, this data can be hot linked (using DDE) to other Windows applications such as WonderWare or Paradox.

- ✓ Read/Write parameters such as a device's Tag Name and timers can be changed in V-Memory then loaded into the device using a single command.

Using the DDE capabilities built into DirectSoft, this data can originate from another Windows applications such as WonderWare or Paradox.

High Performance

The SDS Network Master is an intelligent Communication CoProcessor module which interfaces with the DL405 CPU using high speed parallel dual port memory. The dual port memory bus of the DirectLogic 405 has a bandwidth which rivals much larger PLCs. This bus can read 256 and write 128 bytes of CoProcessor dual port memory every scan. The use of dual port memory frees the SDS Network Master from the overhead often associated with communicating with a ladder logic CPU.

The SDS Network Master's 26 MHz processor executes instructions at up to 6.5 MIPS. This insures the SDS Network Master is not a limiting factor in most applications.

SDS Network Master Module Specifications, F4-SDS				
Communication Rate	125K, 250K, 500K, 1M bps			
Maximum Distance	Rate	Devices	Trunk	Drop
	125K	64	1600'	24'
	250K	64	800'	12'
	500K	64	400'	6'
	1M	32	100'	3'
Protocol	SDS, Honeywell Micro Switch			
Error Detection	CRC error checking and other techniques provide for an undetected bit error rate near zero.			
Status Indication LEDs	POWER (green) ON-LINE (green) NODE ERR (red) (These multi-function LEDs are described on page ??)			
Port	9 Pin			
Maximum Number of F4-SDSs per DL405 CPU	8 Installed in CPU Base			
I/O Configuration Range	16 to 64 Inputs 8 to 48 Outputs			
Impact on PLC Scan Time	Minimal to 3 msec maximum each F4-SDS module			

CHAPTER 2: CONFIGURATION

SLOT DEPENDENT CONFIGURATION

The SDS Network Master is configured using a block of slot dependent configuration V-Memory locations in the DL405 CPU. These locations should be initialized before the SDS Network Master is used. The following table shows the V-Memory locations associated with each slot.

These memory locations must be made retentive if the module should operate when the PLC powers up in program mode.

Slot Dependent V-Memory Locations

Slot	Extended Operations Pointer	Communication Rate Code	Error Code	OnLine/OffLine Status Table Pointer
0	V7660	V7670	V7710	V7730
1	V7661	V7671	V7711	V7731
2	V7662	V7672	V7712	V7732
3	V7663	V7673	V7713	V7733
4	V7664	V7674	V7714	V7734
5	V7665	V7675	V7715	V7735
6	V7666	V7676	V7716	V7736
7	V7667	V7677	V7717	V7737

Extended Operations Pointer

The Extended Operations Pointer is a constant that specifies where the parameters which control the extended functions of the SDS Network Master are located (See Appendix B: Extended Operations). This location should be initialized on the first PLC scan. The value loaded is a constant that corresponds to a V-Memory location. The following example sets the Extended Operations Pointer to V7000 for a SDS Network Master installed in slot 4.

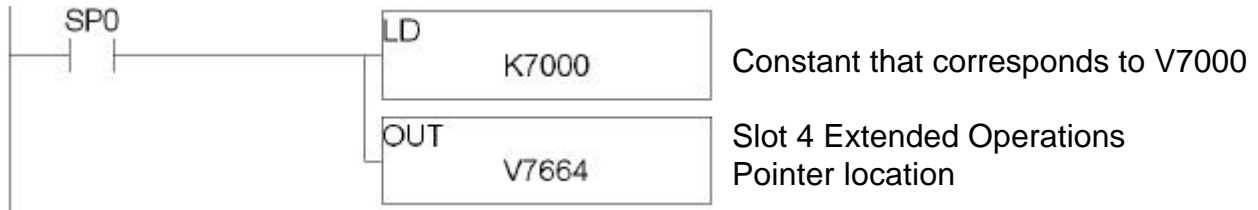

Communication Rate Code

The Communication Rate Code specifies the communication bit rate the SDS Network Master will use. This location should be initialized on the first PLC scan. The value loaded is a constant from the following Communication rate code table. The following example sets the communication rate to 1M bps for a SDS Network Master installed in slot 4.

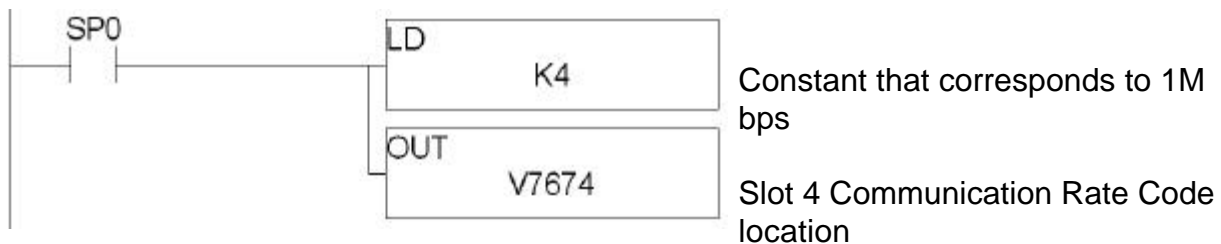

Communication Rate Code Table	
Code	Bit Rate
1	125K bps
2	250K bps
3	500k bps
4	1M bps

The communication rate only needs to be programmed in the SDS Network Master. Then on power-up, the Master will automatically set all the SDS devices on the network to the programmed communication rate.

Error Code

The high byte of the Error Code location contains the SDS Network Master Module firmware version number.

If an error is detected by the module's self diagnostics then an error code is placed in the low byte of the Error Code V-Memory location. The low byte is normally zero (no errors).

The Error Code location is not written to until the module receives the first WX instruction from the PLC. It will also not write to this location if the slot dependent configuration data is incorrect or if the PLC is in program mode. Please refer to Trouble Shooting beginning on page 20 for additional information.

Possible error codes are listed in the Error Code Table.

Error Code Table	
Error Code	Description
0	WX Executed Without Errors
1	Invalid Number of Inputs
2	Invalid Number of Outputs
3	Invalid Input Address
4	ROM CheckSum Error
5	Power-Up WDT Time-Out has Occurred
6	Severe Communication Problem in SDS Bus
7	Number of SDS Inputs Greater than PLC Block Size
8	Invalid Extended Operation Configured
9	Power-up WX instruction is Extended Operations, Output address and number of I/O expected
10	Invalid OnLine/OffLine Status Table Address in slot dependent location (V7730-V7737)
11	SDS Address change failed, duplicate address
12	SDS Address change failed, node does not exist.

A firmware version 1.0 module installed in slot 3 would place 1002 in V7713 if the programmed number of outputs was invalid.

OnLine/OffLine Status Table Pointer

The SDS Network Master reports the status of all configured nodes starting at the location specified by the OnLine/OffLine Status Table Pointer.

At power-up, the SDS Network Master trains all the devices on the network with the programmed communication rate, self tests the network, then determines which devices are online.

An ON bit in the OnLine/OffLine Status Table indicates that a device is online, an OFF bit indicates that a device is offline. If any device goes offline, the red NODE ERR led will turn on solid.

Devices may not be added to the network with power applied.

The first V-Memory location of the OnLine/OffLine Status Table Pointer is the OnLine/OffLine status for the first 16 SDS inputs. There is one V-Memory location for every 16 SDS inputs.

The next V-Memory location in the status table contains the OnLine/OffLine status for the first 16 SDS outputs. There is one V-Memory location for every 16 SDS output devices.

The following example sets the OnLine/OffLine Status Pointer to V2000 for a SDS Network Master installed in slot 4.

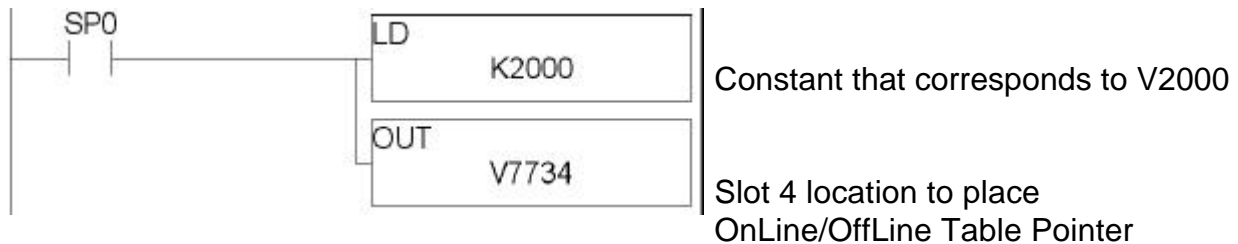

The online status bits can be used in conjunction with a devices ON/OFF status bits to interlock the operation of the device.

Extended SDS Bus Diagnostics

The SDS Network Master Module writes extended diagnostic information to the three V-Memory locations after the last output OnLine/OffLine status V-Memory location.

Bus at Limit This counter is normally 0.

A non-zero value indicates there is too much message traffic for the current communication rate. Should this happen, increase the communication rate or reduce the amount of message traffic.

Message traffic can be reduced in several ways. The Cyclical Timer can be used to control the repeat rate of discrete input devices. The Batch Counter can be used to pre-scale (divide up) discrete inputs used for counting. Also, the de-bounce timers can be used to prevent input chatter.

Over-runs This counter is normally 0.

A non-zero value indicates that messages are arriving faster than the SDS Network Master can process them. Should this happen, reduce the communication rate or reduce the amount of message traffic (see Bus at Limit)

Bus Errors This counter is normally 0.

A non-zero value indicates that there is a high percentage of communication errors on the bus.

SDS NETWORK MASTER OPERATION RUNG

The SDS Network Master is operated using a single rung of ladder logic. This rung specifies the slot where the F4-SDS is installed, the number of SDS input bytes, the number of SDS output bytes, the DL405 V-Memory location of the first SDS output, and the V-Memory location of the first SDS input.

Slot Dependent BUSY Relay

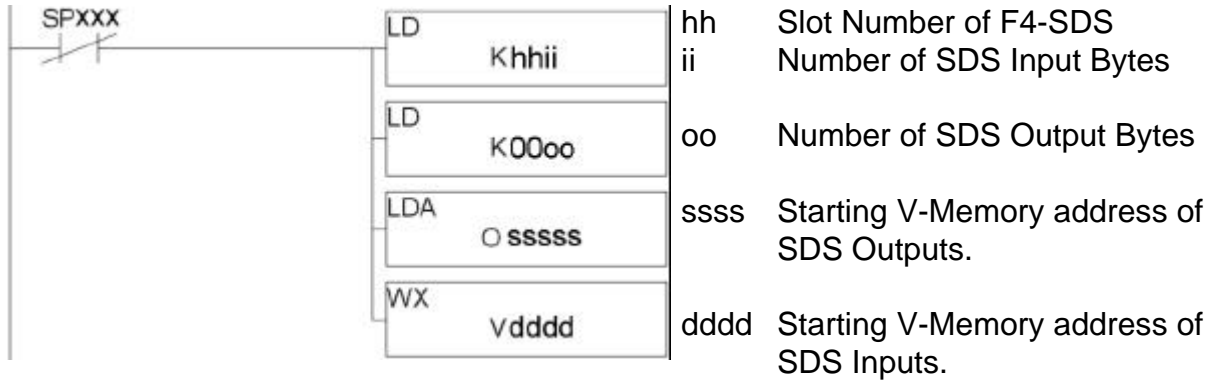

The slot dependent BUSY relay should be included in the WX rung. The following table shows the relay to use for each of the eight possible slots where the F4-SDS can be installed.

Special Purpose (SP) Data Communications Relays								
Slot	0	1	2	3	4	5	6	7
BUSY	120	122	124	126	130	132	134	136
ERROR	121	123	125	127	131	133	135	137

If the F4-SDS module has not processed the last WX instruction executed, the Special Purpose (SP) BUSY relay associated with the slot where the F4-SDS module is installed is turned on. Normally the SDS Network Master communicates with the PLC every scan. It is possible that under conditions of severe network loading, the BUSY relay may be energized. This coil is normally off.

If the F4-SDS module is not communicating with the PLC then the ERROR relay associated with the SDS's slot is energized. If the ERROR relay is energized please refer to the trouble shooting section.

SDS Network Master Slot and Number of SDS Inputs

The first LD (LOAD) instruction of the configuration rung uses a high byte and a low byte to specify the module's slot number and the SDS number of input bytes.

The high byte (hh) is the slot where the F4-SDS is installed. The range of valid slot numbers is 0 to 7.

The low byte (ii) is the number of input bytes. This is an even number ranging from 2 to 8.

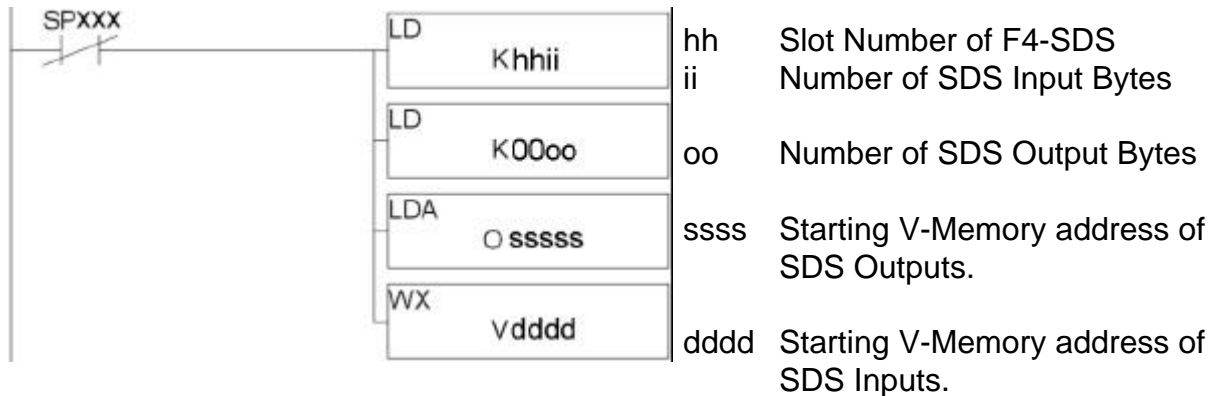

NOTE: All SDS input device addresses must be less than or equal to the highest possible input address based on the number of input bytes specified.

If 2 input bytes (16 devices) are specified then the highest input address is $2 \times 8 = 16$.

The number of input bytes plus the number of outputs bytes must be ≤ 8 .

SDS Addressing Table			
Input Address Range	Number of Input Bytes	Output Address Range	Number of Output Bytes
1-16	2	17-64	1-6
1-32	4	33-64	1-4
1-48	6	49-64	1-2
1-64	8	0	1*

- If the number of input or output bytes is zero, the WX rung is ignored by the PLC. When the number of input bytes is 8, the SDS Network Master ignores the number of output bytes.

Number of SDS Outputs

The second LD (LOAD) instruction of the configuration rung specifies the number of output bytes. The valid range for the number of output bytes is 1 to 6.

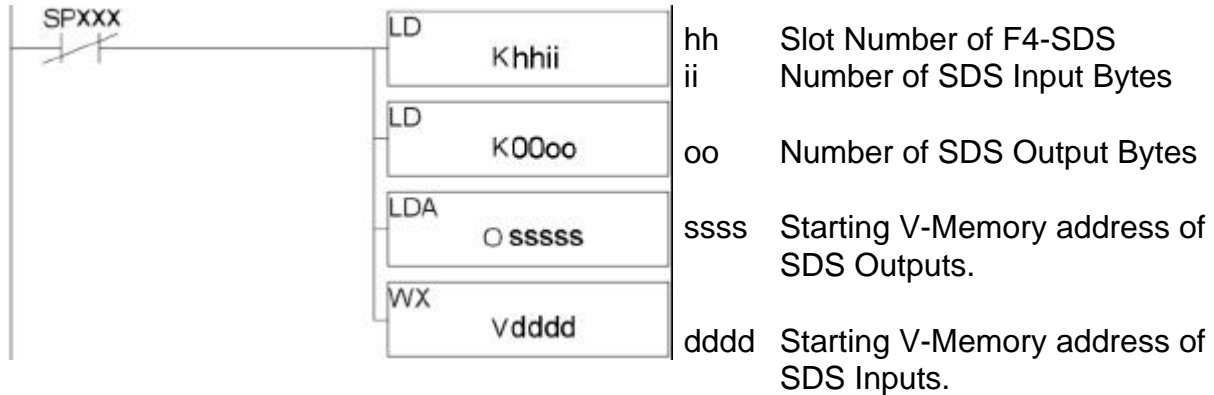

NOTE: All SDS output device addresses must be greater than the highest possible input address and less than or equal to the maximum configured output address.

If 2 input and 2 outputs bytes are specified then the highest output address is $2 \times 8 + 2 \times 8 = 32$.

The number of input bytes plus the number of outputs bytes must be ≤ 8 .

SDS Addressing Table			
Input Address Range	Number of Input Bytes	Output Address Range	Number of Output Bytes
1-16	2	17-64	1-6
1-32	4	33-64	1-4
1-48	6	49-64	1-2
1-64	8	0	1*

- If the number of input or output bytes is zero, the WX rung is ignored by the PLC. When the number of input bytes is 8, the SDS Network Master ignores the number of output bytes.

Start Address of SDS Outputs

The LDA (LOAD ADDRESS) instruction of the configuration rung specifies the starting V-Memory address where SDS outputs come from. Any valid V-Memory reference may be placed here.

The O in the LDA instruction stands for Octal. To specify V1400 as the starting data address use O1400. To specify V40500 as the starting address use O40500.

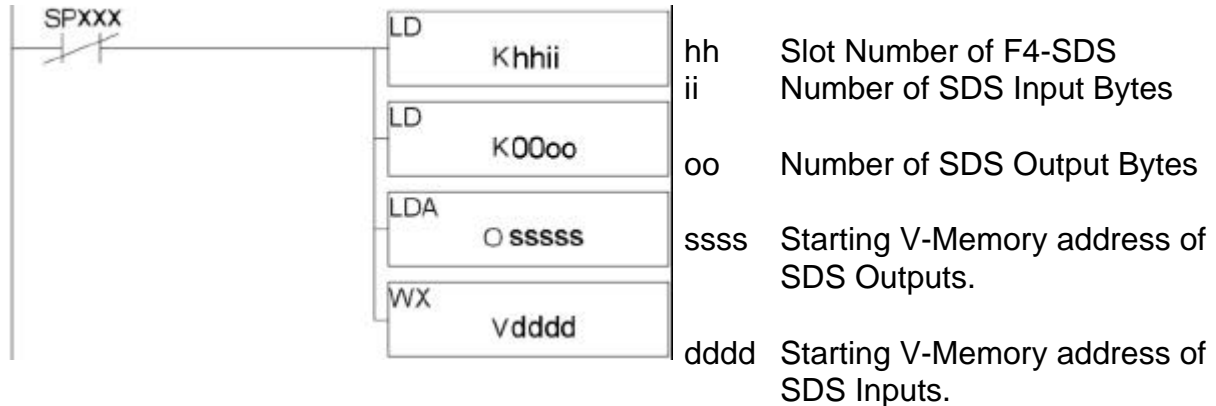

Start Address of SDS Inputs

The WX instruction of the configuration rung specifies the V-Memory location where SDS inputs will be placed. Any valid V-Memory reference may be placed here.

To specify V1400 as the starting data address use V1400. To specify V40400 as the starting address use V40400.

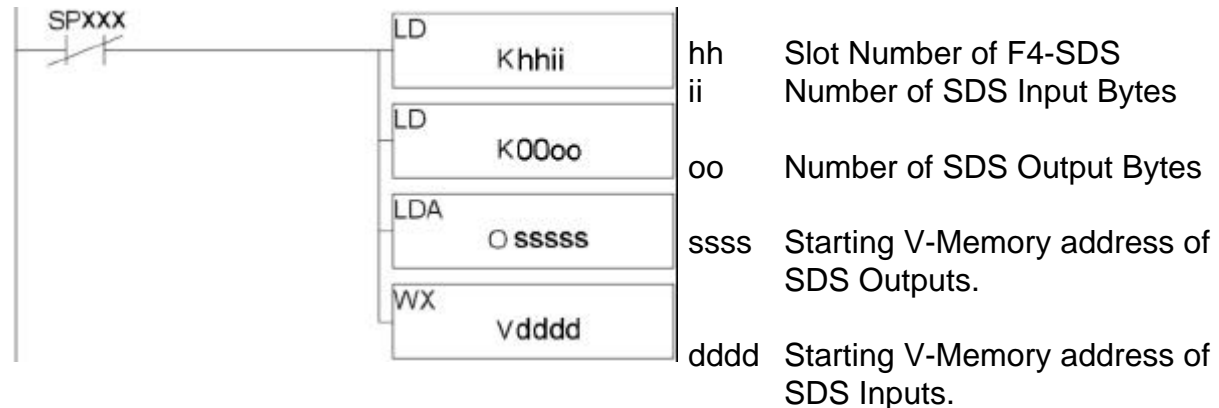

NOTE: If enabled, the asynchronous high speed counters use the 8 V-Memory locations following the last SDS input V-Memory location.

See Appendix B for more information on Extended Operations.

Location of SDS Network Master Operation Rung

For normal operation, the SDS Network Master Operation WX rung should be executed every scan.

When the WX rung is executed, the status of the specified outputs are saved for later output to the SDS Network Master. For this reason the WX rung is normally placed at the end of the program. If the WX rung is placed before the ladder logic which changes the state of one of the SDS outputs, then the SDS output change of state will be delayed by one additional PLC scan time.

The following diagram shows how the SDS inputs and outputs fit into the DL405 CPU run mode operation.

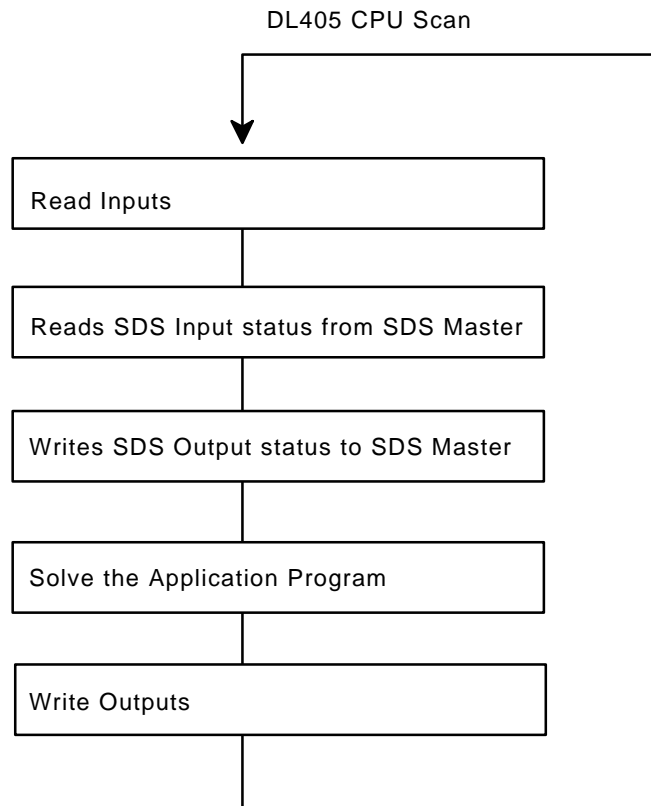

Example: The SDS Network Master Module is installed in slot 4.

Extended Operations begin at V7000 (optional).

The communication rate is 1M bps.

The OnLine/OffLine Status table begins at V2000.

There are 16 SDS inputs and 16 SDS outputs on this network.

SDS inputs 1-16 are written to X260-X277 (V40413).

SDS outputs 17-32 are read from Y460-Y477 (V40523).

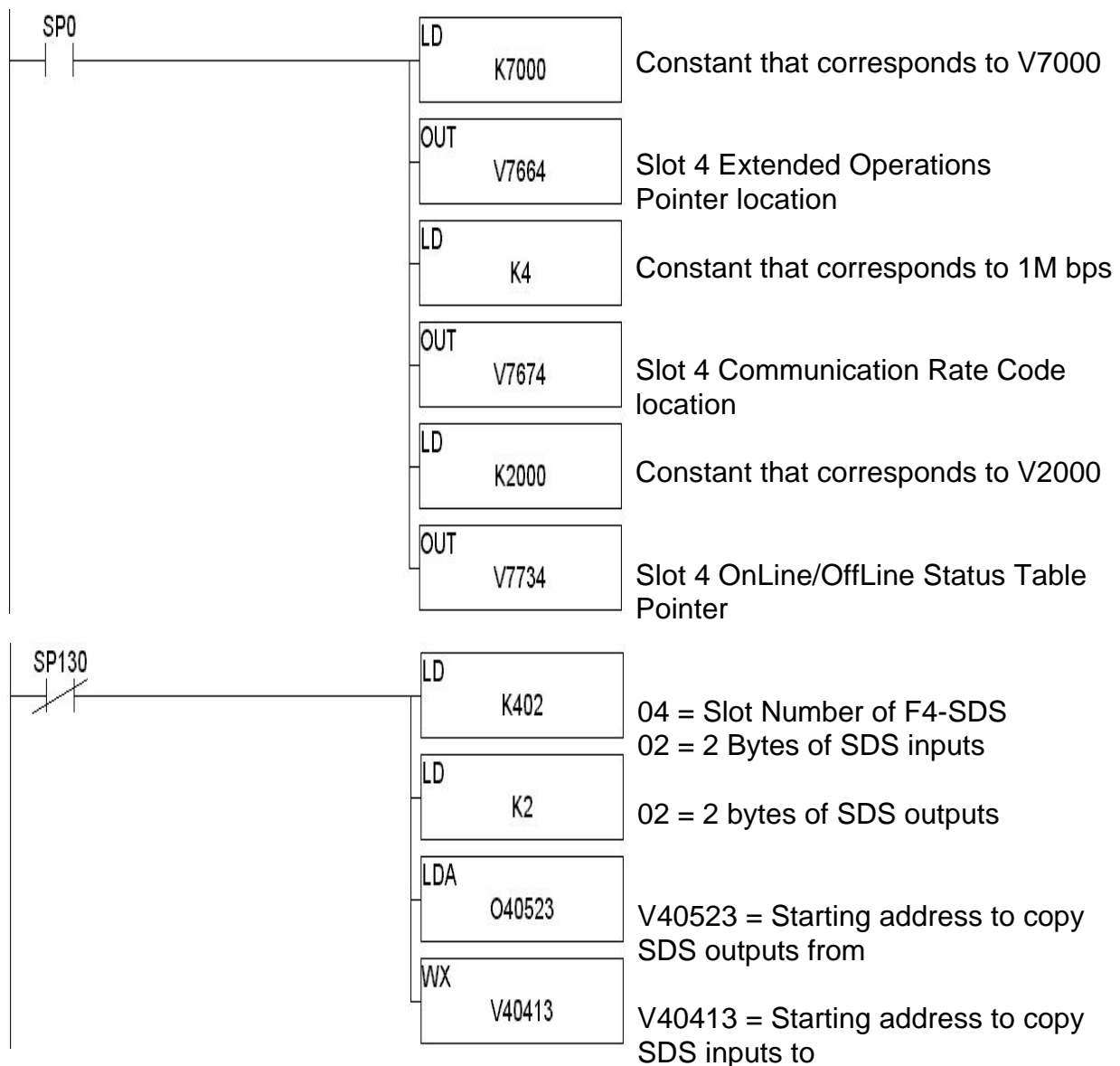

Example SDS Network Master V-Memory Map			
OnLine/OffLine Status Table	SDS Inputs	SDS Outputs	Extended Operations
V2000 Inputs 1-16	V40413 X260-X277	V40523 Y460-Y477	V7000 Control Codes
V2001 Outputs 17-32	V40414 Input 1 Count		V7001 Counter Control
V2002 Bus at Limit	V40415 Input 2 Count		V7002 Database Pointer
V2003 Over-runs	V40416 Input 3 Count		
V2004 Bus Errors	V40517 Input 4 Count		
	V40420 Input 5 Count		
	V40421 Input 6 Count		
	V40422 Input 7 Count		
	V40423 Input 8 Count		

SDS input devices with addresses of 1 to 16 correspond to DL405 input contacts X260 to X277 respectively.

SDS output devices with addresses of 17 to 32 are activated by DL405 output coils Y460 to Y477.

V2000 contains the OnLine/OffLine status of the SDS input devices. The least significant bit of V2000 corresponds to the OnLine/OffLine status of SDS input 1. The most significant bit of V2000 corresponds to the OnLine/OffLine status of SDS input 16. If the bit is ON then the associated device is online, if the bit is OFF the associated device is offline.

Since 2 bytes were configured for inputs, only 1 V-Memory location is required for OnLine/OffLine status of inputs (V2000). The next V-Memory location (V2001) is the start of the OnLine/OffLine status of SDS output devices. If an odd number of bytes are configured for inputs, the OnLine/OffLine status of outputs will start at the next V-Memory location.

CHAPTER 3: PORT CONNECTIONS AND NETWORK WIRING

The F4-SDS Network Master interfaces to the SDS Network using a 9-pin D type connector. This connector provides bus data connections to the network.

Typically the communications cable is connected to a terminal block in the control panel. The bus power supply and the cable to the F4-SDS are connected to this terminal block. Please refer to the diagram on the following page.

SDS NETWORK MASTER CONNECTIONS

The bus power is not supplied by the SDS Network Master. No connection to pins 5 or 6 is required. These pins may be used to simplify daisy chain connections.

Pin Number	Description	Symbol
1	BUS COMMUNICATIONS (+)	BUS +
2	BUS COMMUNICATIONS (+)	BUS +
3	BUS COMMUNICATIONS (-)	BUS -
4	BUS COMMUNICATIONS (-)	BUS -
5	BUS POWER (+)	PWR +
6	BUS POWER (+)	PWR +
7	COM BUS POWER (-)	PWR -
8	COM BUS POWER (-)	PWR -
9	SHIELD	SHLD

NOTE: Pins 1-2, 3-4, 5-6, and 7-8 are internally connected to simplify daisy chain connections.

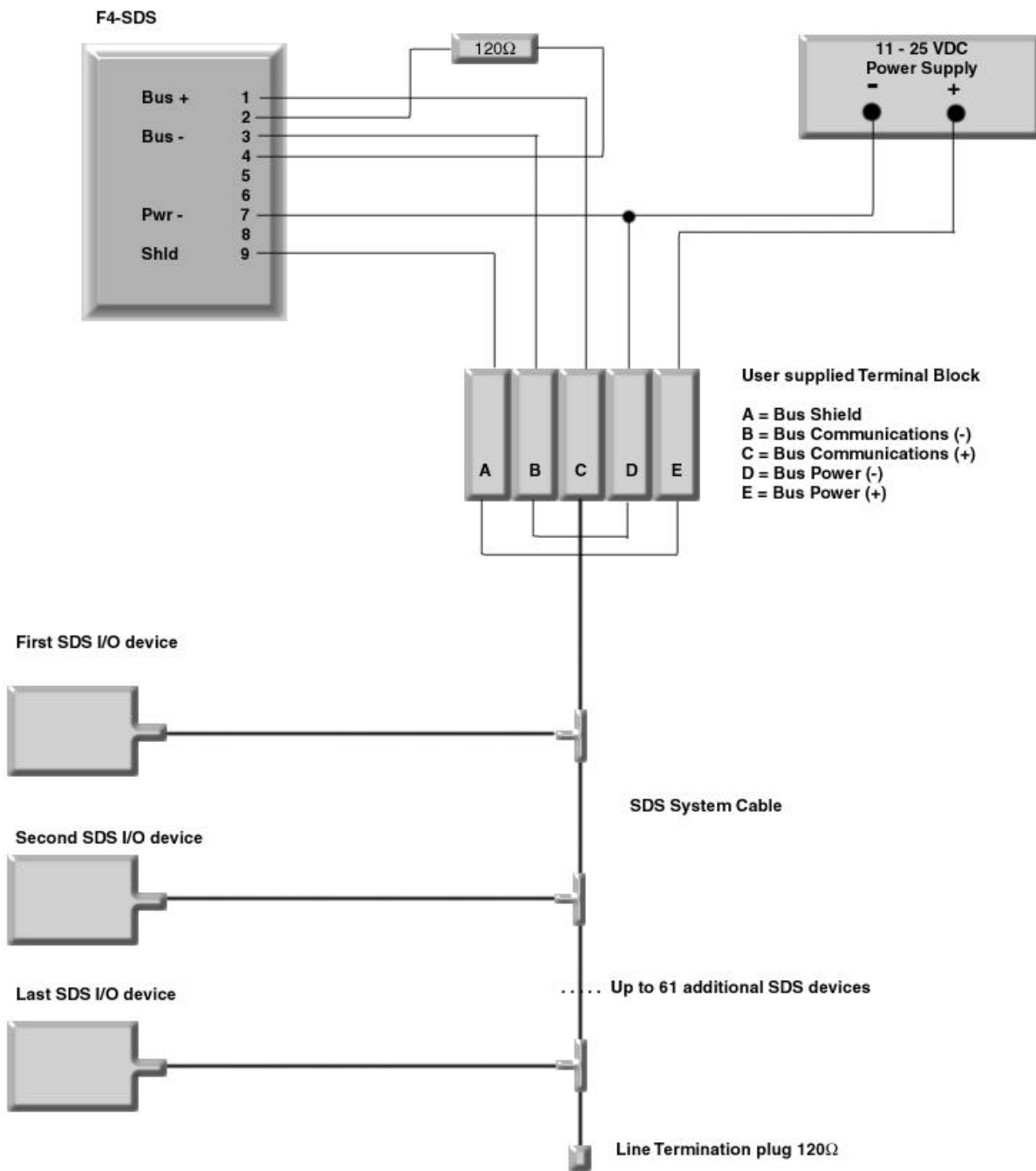

SDS BUS CONNECTION

APPENDIX A: TROUBLE SHOOTING

DESCRIPTION OF NORMAL OPERATION

At power up, the POWER LED is ON.

The ON-LINE LED flashes ON very briefly. This indicates that a valid slot dependent configuration has been read.

The NODE ERR LED comes ON for about one second then goes OFF. This indicates that the module is setting the communication rate of all devices on the network.

The ON-LINE LED comes ON for about one second then goes OFF for about one second and repeats this pattern as long as no errors are detected.

The slot dependent module BUSY and ERROR special relays are OFF.

The module writes the firmware version to the slot dependent V-Memory location with no error codes.

The module signs on in the I/O configuration table as "D4-DCM".

COMMON SDS MASTER PROBLEMS AND SOLUTIONS

Problem: "No Heartbeat"

Symptom: At power-up, The ON-LINE LED flashes ON briefly then goes OFF. The NODE ERR LED never comes ON.

Cause 1: The SDS Network Master Operation rung (WX) is not executing.

Solution: Add the WX rung if it does not exist.

Verify that the special relay (SP) used is for the slot that the module is installed in.

Verify that the PLC is in RUN mode. The WX instruction is not executed while the PLC is in program mode.

Verify that the WX rung values are valid. The WX rung will not execute if the number of inputs or the number of outputs specified is zero.

Cause 2: The SDS cable is defective or disconnected before the first device.

Solution: Repair the SDS Network cable then power cycle the network. At least one SDS device must be connected to the SDS Network Master.

Problem: "Railroad Lights"

Symptom: At power-up, the ON-LINE and NODE ERR LEDs flash back and forth.

Cause: Slot dependent configuration V-Memory locations are invalid.

Solution: Check the slot dependent V-Memory locations for valid values.

Slot Dependent V-Memory Locations	Valid values
V7660-V7667 Extended Operations Pointer	K1400 to K7377
V7670-V7677 Communication Rate Code	K1 to K4
V7730-V7737 OnLine/OffLine Status Table Pointer	K1400 to K7377

Problem: "Power LED Goes OFF"

Symptom: The POWER LED flashes about every ten seconds followed by a brief flash of the ON-LINE LED.

The ERROR relay associated with the SDS module's slot is energized.

Cause: SDS Network cable is defective or disconnected before the first device connection.

Solution: Repair or reconnect the SDS Network cable then power cycle the network.

Problem: "Red NODE ERR LED Stays ON"

Symptom: The red NODE ERR LED comes ON solid. The ON-LINE LED continues to flash normally at one second intervals.

Cause: A device that was previously online is now offline.

Solution: Reconnect or replace device.

Problem: "Red NODE ERR LED Flashes"

Symptom: The ON-LINE LED is ON solid and the red NODE ERR LED is flashing very fast.

Cause: There is an error in the WX rung.

Solution: Look at the slot dependent error code location to determine the exact error and take the appropriate action.

Error Code Table	
Error Code	Description
0	WX Executed Without Errors
1	Invalid Number of Inputs
2	Invalid Number of Outputs
3	Invalid Input Address
4	ROM CheckSum Error
5	Power-Up WDT Time-Out has Occurred
6	Severe Communication Problem in SDS Bus
7	Number of SDS Inputs Greater than PLC Block Size
8	Invalid Extended Operation Configured
9	Power-up WX instruction is Extended Operations, Output address and number of I/O expected
10	Invalid OnLine/OffLine Status Table Address in slot dependent location (V7730-V7737)
11	SDS Address change failed, duplicate address
12	SDS Address change failed, node does not exist.